

A MOBILE HOLDING CAGE FOR SILVER GULLS

Shorebird Study Group, C/- 'Stoney', Campania, Tasmania 7026

Received 14 January, 1988

During the last three years, the Shorebird Study Group (Bird Observers Association of Tasmania) has been catching Silver Gulls *Larus novaehollandiae* with a cannon net on tip sites around Hobart. For our first few catches we used our wader cages to hold the birds. This proved to be most unsatisfactory because of the problem of trying to secure the cages to the rock hard surface of the tips. The cages had to be held in place with

rocks, pieces of machinery, lumps of wood, etc., which was very time consuming. In addition, the birds' feathers became soiled with mud formed by their excreta and the earthen floor. We then thought of using a normal car trailer, which has proved most successful.

The tray of the trailer is divided into four compartments with wooden boards (Figs. 1a and 2). This prevents the total catch of gulls from crowding into one corner. The floor of the trailer is lined with a thick layer of newspaper to absorb excreta and the trailer is covered with a tarpaulin, which is tied down with the tie ropes, 'A' (Fig. 2) to the front, back and sides of the trailer (Fig. 1b). The corner flaps 'B' (Fig. 2) are tied down when a compartment is full of birds. A very important feature of our trailer is that air is able to circulate through the compartments between the gap formed by the top of the sides of the trailer and the bar 'C' (Fig. 2), to which the tarpaulin is tied.



Figure 1. Photographs showing details of operation of holding trailer (a) tarpaulin removed to show the wooden boards which form the four compartments; (b) tarpaulin cover affixed to trailer with corner flaps open; (c) cover trailer under shade for processing of birds.

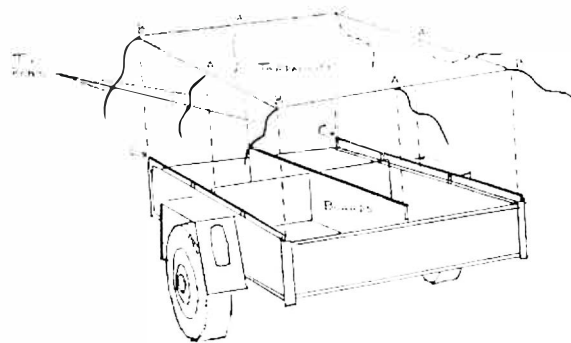

Figure 2. Fixing position of boards and tarpaulin on trailer.

As soon as the cannon net is fired, the trailer is driven to a suitable position and a maximum of 25 gulls is placed in each compartment and the flaps of the tarpaulin secured. If the day is hot, the trailer is driven to the nearest shade (Fig. 1c), where we process the birds. On completion the newspapers are rolled up and dumped on the tip, leaving a remarkably clean trailer!